

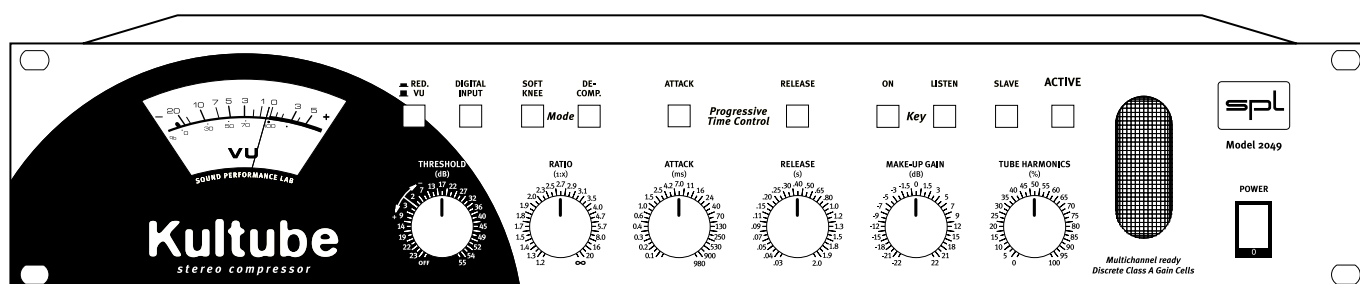

# Manual



# Kultube

Model 2049

Stereo Compressor

Version 1.3 – 05/2011

R & D: Ruben Tilgner

The information in this document has been carefully verified and is assumed to be correct. However Sound Performance Lab (SPL) reserves the right to modify the product described in this manual at any time. Changes without notice. This document is the property of SPL and may not be copied or reproduced in any manner, in part or full without the authorization of SPL.

Limitations of Liability:

In no event will SPL be liable for any damages, including loss of data, lost profits, cost of cover or other special, incidental, consequential or indirect damages arising from the use of the unit, however caused and on any theory of liability. This limitation will apply even if SPL or an authorized dealer has been advised of the possibility of such damage.

#### **SPL electronics GmbH**

Sohlweg 80, 41372 Niederkrüchten

Fon. (0 2163) 9 83 40, Fax (0 2163) 98 34 20

E-Mail: info@spl.info, Web: spl.info

#### **CE Declaration of Conformity**

The construction of this unit is in compliance with the standards and regulations of the European Community.



#### **Notes on environmental protection**

At the end of its operating life, this product must not be disposed of with regular household waste but must be returned to a collection point for the recycling of electrical and electronic equipment. The “wheelie bin” symbol on the product, user’s manual and packaging indicates that. The materials can be re-used in accordance with their markings. Through re-use, recycling of raw materials, or other forms of recycling of old products, you are making an important contribution to the protection of our environment. Your local administrative office can advise you of the responsible waste disposal point.



**WEEE Registration: 973 349 88**

© 2011 SPL electronics GmbH. All rights reserved.

---

<b>Important Security Information</b>	<b>4</b>
<b>Installation</b>	<b>6</b>
Progressive Time Control	7
Discrete Gain Cells	7
Tube Harmonics	7
Master/Slave Mode	7
Features	7
<b>Introduction</b>	<b>7</b>
<b>Connections</b>	<b>8</b>
Analog XLR and TRS jacks	9
Side-chain inputs	10
Multi Channel Link	10
Hum? Ground Lift!	10
RED/VU	11
DIGITAL INPUT	11
SOFTKNEE	11
DE-COMP.	11
<b>Control Elements</b>	<b>11</b>
Progressive Time Control: ATTACK	12
Progressive Time Control: RELEASE	12
KEY ON	12
KEY LISTEN	12
SLAVE	12
ACTIVE	12
THRESHOLD	13
RATIO	13
ATTACK	13
RELEASE	13
MAKE UP GAIN	13
TUBE HARMONICS	14
<b>Operation</b>	<b>14</b>
Understanding and enjoying the Kultube	14
The Threshold control	14
The Ratio control	15
The Attack control	16
Progressive Time Control (Attack)	17
The Release control	18
Progressive Time Control (Release)	19
Summed signal processing	21
Single track and subgroup processing	21
<b>Applications</b>	<b>21</b>
Sidechain	22
Multi-channel and 5.1 surround applications	23
<b>Specifications</b>	<b>24</b>

---

## Important Security Information

---



Please note and retain this manual. Carefully read and follow all of the safety and operating instructions before you use the machine.

Be doubly careful to follow all warnings and special safety instructions noted in this manual and on the unit.

**Connections:** Only use the connections as described. Other connections can lead to health risks and equipment damage.

**Water And Humidity:** Do NOT use this machine anywhere near water (for example near a wash basin or bath, in a damp cellar, near swimming pools, or the like). In such cases there is an extremely high risk of fatal electrical shocks!

**Insertion Of Foreign Objects Or Fluids:** NEVER allow a foreign object through any of the machine's chassis openings. You can easily come into contact with dangerous voltage or cause a damaging short circuit. NEVER allow any fluids to be spilled or sprayed on the machine. Such actions can lead to dangerous electrical shocks or fire!

**Opening the Machine:** Do NOT open the machine housing, as there is great risk you will damage the machine, or – even after being disconnected – you may receive a dangerous electrical shock!

**Electrical Power:** Run this machine ONLY from sources which can provide proper power at the prescribed rating. When in doubt about a source, contact your dealer or a professional electrician. To be sure you have isolated the machine, do so by disconnecting the power cord from your wall connection. Be sure that the power cord plug is always accessible. When not using the machine for a longer period, make sure to unplug it from your wall power socket.

**Power Cord Protection:** Make sure that your power cord is arranged to avoid being stepped on or any kind of crimping and damage related to such event. Do not allow any equipment or furniture to crimp this power cord.

**Power Connection Overloads:** Avoid any kind of overload in connections to wall sockets, extension or splitter power cords. Always keep manufacturer warnings and instructions in mind. Overloads create fire hazards and risk of dangerous shocks!

**Lightning:** Before thunderstorms or other severe weather, disconnect the machine from wall power (but to avoid life threatening lightning strikes, not during a storm). Similarly, before any severe weather, disconnect ALL the power connections of other machines and antenna and phone/network cables which may be interconnected so that no lightning damage or overload results from such secondary connections.

**Air Circulation:** Chassis openings offer ventilation and serve to protect the machine from overheating. NEVER cover or otherwise close off these openings. NEVER place the machine on a soft surface (carpet, sofa, etc.). Make sure to provide for a mounting space of 4-5 cm/2 inches when mounting the machine in racks or cabinets.

**Controls And Switches:** Operate the controls and switches only as described in the manual. Incorrect adjustments outside safe parameters can lead to damage and unnecessary repair costs. Never use the switches or level controls to effect excessive or extreme changes.

**Repairs:** Unplug the machine and immediately contact a qualified technician when you think repairs are needed – or when moisture or foreign objects may accidentally have gotten in to the housing, or in cases when the machine may have fallen and shows any sign of having been damaged. This also applies to any situation in which the machine has not been subjected to any of these unusual circumstances but still is not functioning normally or its performance is substantially altered.

In cases of damage to the power cord or its plug, first consider turning off the main circuit breaker before unplugging the power cord.

**Replacement/Substitute Parts:** Be sure that any service technician uses original replacement parts or those with identical specifications as the originals. Incorrectly substituted parts can lead to fire, electrical shock, or other dangers, including further equipment damage.

**Safety Inspection:** Be sure always to ask a service technician to conduct a thorough safety check and ensure that the state of the repaired machine is in all respects up to factory standards.

**Cleaning:** In cleaning, do NOT use any solvents, as these can damage the chassis finish. Use a clean, dry cloth (if necessary, with an acid-free cleaning oil). Disconnect the machine from your power source before cleaning.

## Installation

---

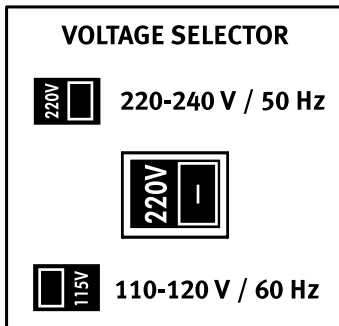

- Side-chain inputs on the front panel
- Slave mode for multi-channel operation

**Be very careful to check that the rear chassis power selection switch is set to the correct local line voltage position before using the unit (230 V position: 220-240 V/50 Hz, 115 V position: 110-120 V/60 Hz)!**

When in doubt about a source, contact your dealer or a professional electrician.

**Before connecting any equipment make sure that any machine to be connected is turned off. Follow all safety instructions from page 5.**

Place the unit on a level and stable surface. The unit's enclosure is EMC-safe and effectively shielded against HF interference. Nonetheless, you should carefully consider where you place the unit to avoid electrical disturbances.

The unit should be positioned so that you can easily reach it, but there are other considerations. Try not to place it near heat sources or in direct sunlight, and avoid exposure to vibrations, dust, heat, cold or moisture. It should also be kept away from transformers, motors, power amplifiers and digital processors. Always ensure sufficient air circulation by keeping a distance of 4-5 cm/2 inches to other units and to the sides of the unit.

## Power Supply

---

Built around a toroidal transformer, the power supply has a minimal electromagnetic field to avoid hum or mechanical noise.

The power supply's output side is filtered by an RC circuit again to extract noise and hum from the supplied electrical power.

6000 µf capacitors smooth out the positive and negative half waves. An additional power supply filter is placed before the power switch to eliminate disturbing interferences.

All signal processing components are supplied with two separate current regulators to exclude influences from the remaining components.

The 220 v current for the tube stage power is smoothed out with 200 µF and stabilized precisely by current regulators. The anode current is switched on after warm up. Both measures ensure a remarkable extension of the tube's lifetime.

The unit's supply voltage can be set to 230 V/50 Hz or 115 V/60 Hz. Check your local power requirements for the appropriate setting. An AC power cord is included to feed the IEC-spec, 3-prong connector. Transformer, AC cord and IEC-receptacle are VDE, UL and CSA approved. The main fuse is rated at 315 mA for 230 v and 630 mA for 115 v. Chassis ground and AC ground can be physically disconnected with the "GND Lift" switch on the rear panel to eliminate hum.

The Kultube user disposes over a unique range of powerful compression tools ranging from subtle unobtrusive processing to very obvious ‘effect’ compressions. Used conventionally or as an effect, in professional recording or mastering applications, the Kultube combines outstanding audio quality with the acclaimed musicality and user-friendliness that SPL units stand for.

Applications cover those of a classic compressor for vocals and instruments, in both mono and stereo, through stereo operation for subgroup processing to stereo mastering and multi-channel/surround projects.

### **Progressive Time Control**

With the unique Progressive Time Control (PTC) option for attack and release, time constants can be optimized by unique circuitry that reacts both to the input signal and to the user settings - for example, fast impulses are intercepted by an attack time as fast as 20  $\mu$ s. PTC can be seen as an interactively controllable automation which is not based on fix presets but reacts to the audio material in a musically useful way.

### **Discrete Gain Cells**

SPL has developed discrete, very high performance gain cells that are used instead of the usual VCAs and the Kultube is the first product to use them. They ensure the highest level of musicality and clarity in signal processing and demonstrate significantly improved distortion values over VCAs.

### **Tube Harmonics**

The adjustable tube saturation of the output stages combined with automatic output level adjustment can produce tube sound effects that range from the delicate to the raucous whilst a useful de-compressor mode can reanimate over-compressed material (such as samples).

### **Master/Slave Mode**

In master/slave mode, any number of devices can be controlled from one master unit.

### **Features**

- Discrete, high performance gain cells instead of industrial VCAs
- Progressive Time Control: interactively controllable automation for Attack and Release parameters
- Adjustable tube saturation with output level adjustment
- Selectable soft or hard knee characteristics
- Unique de-compression mode
- Large VU meter displays gain reduction or (mono summed) output level

The Kultube can optionally be equipped with a 24 bit/96 kHz converter module

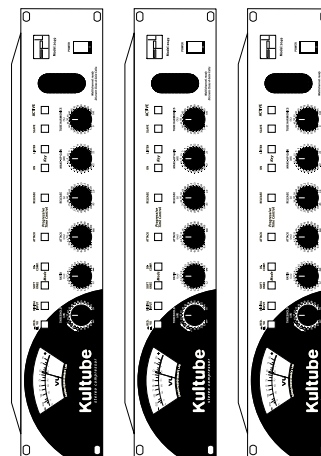
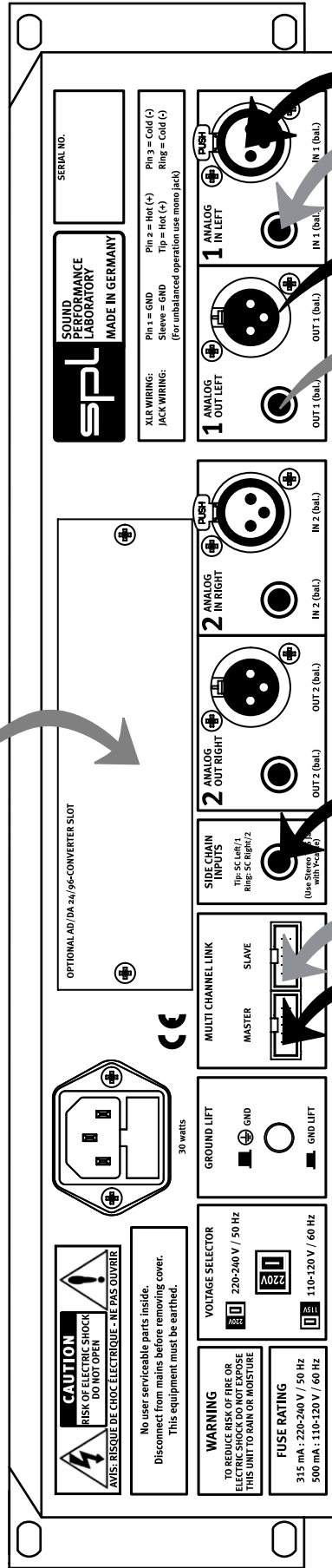

Further Kultubes as slaves in multi-channel link mode

Connector for external processing units (e. g. Equalizer)

Connection to console: Insert Sends ... Analog Inputs Insert Returns ... Analog Outputs

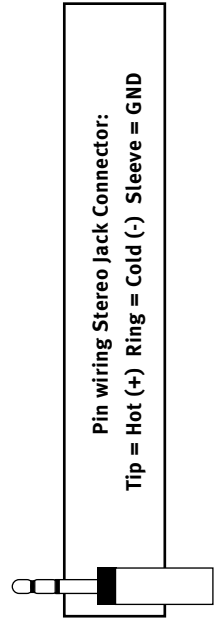
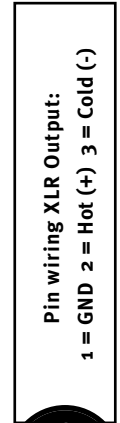
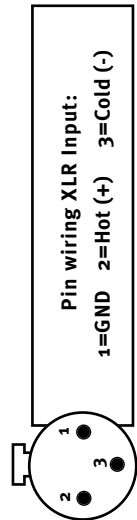

Again, while Kultube’s housing is EMV safe and protects against HF interferences, proper placement of the unit is very important. Before connecting the Kultube or any other equipment turn off all power. Adjust the voltage setting on the back so that it corresponds with your local electrical power conditions.

The following graph shows the correct wiring for connecting unbalanced signals to the balanced XLR connectors:

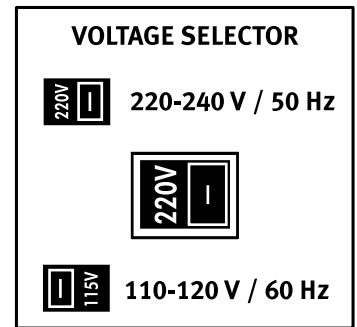
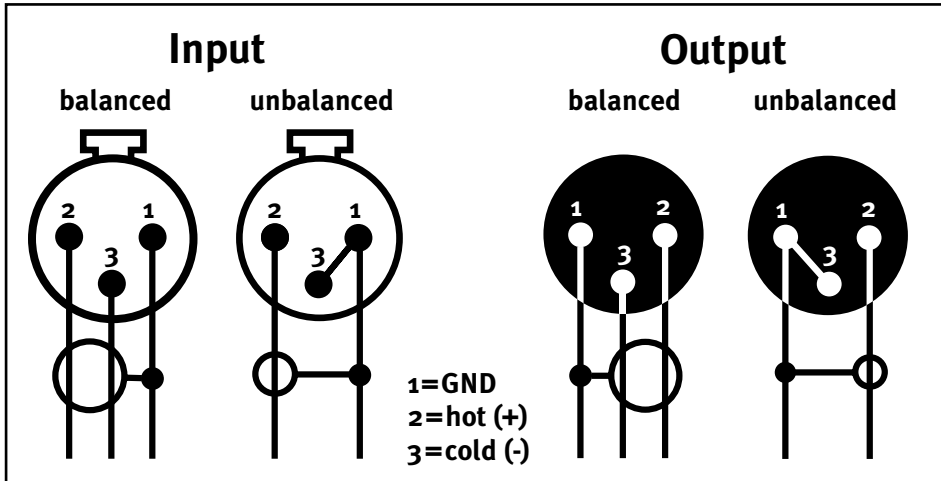

Alternatively unbalanced signals can be connected with mono Jack connectors to the balanced Jack sockets.

**Sockets & Rear Switch**

**Analog XLR and TRS jacks**

Symmetrical XLR and TRS jacks are used for analog in- and outputs. An analog mixing console is generally connected here (Insert Send/Return). Since the TRS and XLR jacks are wired in parallel, unbalanced operation of the TRS jack will have the same effect on the XLR jack and vice-versa. The Kultube is configured for a nominal level of +4dBu and can handle an input level of max. 25 dBu, with max. +23 dBu available on the output. It is recommended to drive the Kultube with a signal level of between 0dBu and 12 dBu – this being the optimum drive range for signal processing in which also the signal-to-noise ratio is the best.

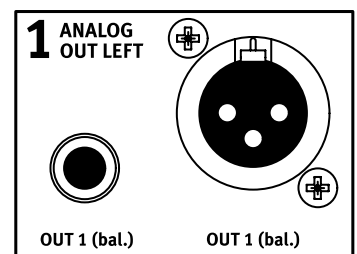
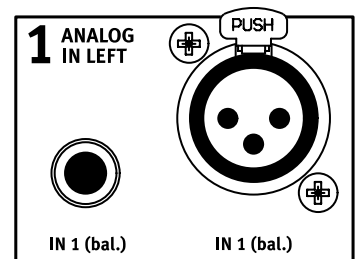

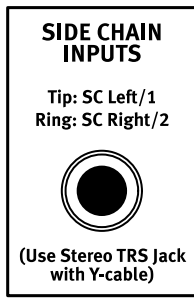

### Side-chain inputs

This jack is used as a side-chain input for connecting an external audio signal to control the Kultube (e. g. an equalizer for frequency dependent processing). It is configured as a stereo TRS jack, with the left channel on the tip and the right channel on the ring.

Ideally you should use a normal insert cable that combines a stereo TRS plug (connected to the Kultube) and two mono TRS plugs (connected to the control device). When using an equalizer you can connect its inputs to the unused jack inputs on the Kultube. In this way both the equalizer and the Kultube get the same signal, since the XLR and TRS jacks are wired in parallel.

To use the side-chain input, activate the KEY ON switch on the front panel. To monitor the signal, activate the KEY LISTEN switch. For other notes on using the side-chain function, see the section on page 20.

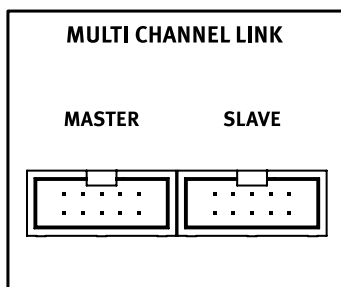

### Multi Channel Link

The MULTI CHANNEL LINK jacks can be used to connect multiple Kultube units for multi-channel operation, so that they can be used together with a master unit. Before connecting the link cable, determine which is the master unit and connect the link cable to the MASTER jack. All linked devices are connected only through the SLAVE jack.

**IMPORTANT WARNING: Always define only one master device! Never connect more than one device through the MASTER jack – otherwise components may be destroyed!**

After you have made the cable connections, the SLAVE switch on the front panel of each slave unit must be activated. From now on all functions of all slave units are controlled by the master.

See page 21 for additional information about multi-channel operation.

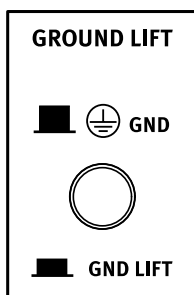

### Hum? Ground Lift!

Hum can be eliminated with the GROUND LIFT switch on the rear of the unit (isolates the internal ground from chassis ground). Hum can occur for example when the Kultube is connected to devices having a different ground potential.

Hum problems can also be avoided however by consistently installing balanced wirings. For this reason the GND lift function is by default not activated.

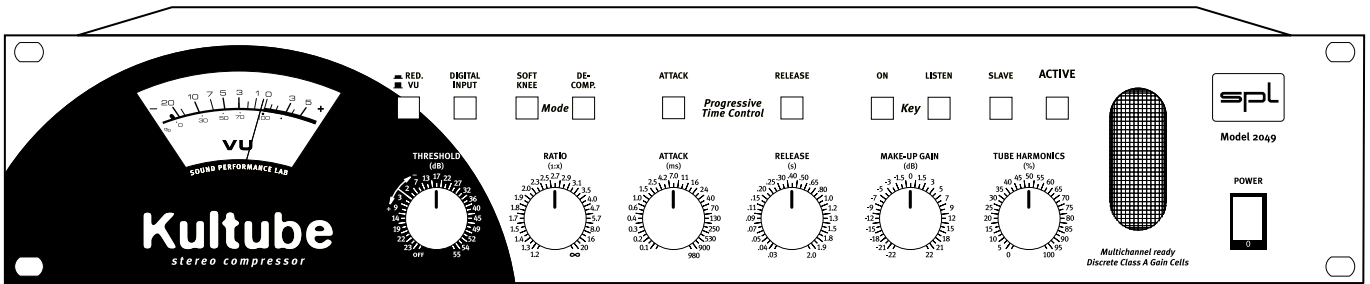

Please note also the information on various controls under „Understanding and enjoying the Kultube“ starting page 12.

### RED/VU

This switch changes the VU meter over to Gain Reduction mode. The indicator needle then jumps to the 0 dB value and moves to the left with increasing compression. The scaled values now refer to gain reduction.

If the RED/VU switch is not pressed, the VU meter indicates the output level.

If neither the RED/VU nor the ACTIVE switch is pressed, the VU meter indicates the input level. In Slave mode gain reduction is controlled by the master device.

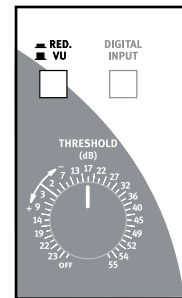

### DIGITAL INPUT

The DIGITAL INPUT switch served to select the converted digital signals as an input source for the Kultube and adds digital in- and outputs, allowing it to be easily integrated into a digital production chain.

**PLEASE NOTE: This switch function only applies to the converter module 2053 which was discontinued in 2005. It does not work with the current AD converter module 2376.**

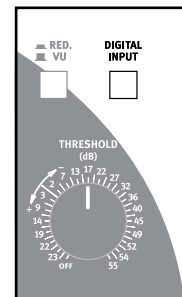

### SOFTKNEE

SOFTKNEE alters the slope of the compressor. Normally the unit operates in hardknee mode, but pressing the SOFTKNEE switch activates the soft-knee mode.

SOFTKNEE provides unobtrusive compression results; the greatest possible loudness however can only be achieved in hard-knee mode. The slope of the curves is shown on page 13.

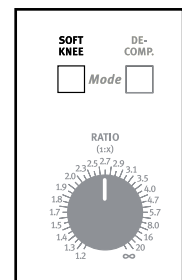

### DE-COMP.

This switch activates Decompression mode. This mode causes the compressor to work in reverse: All signals above the preset threshold become louder, and the Ratio controller determines the intensity of the volume increase. Please note that the Make-Up controller now works exactly in reverse: the signal becomes softer when the controller is turned to the right and louder when turned to the left.

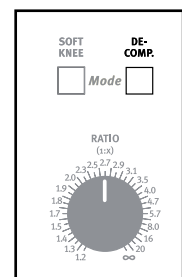

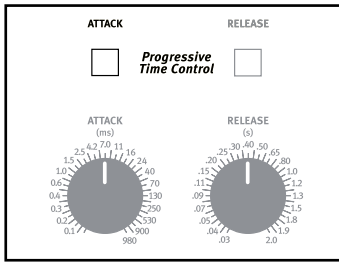

**Progressive Time Control: ATTACK**

This function allows to switch in an adjustable automatization of the time constants which is set up with the ATTACK control.

Put simply you can now influence the compression intensity for rapid signal increases, or when the function is turned off determine the time until a certain compression level is reached.

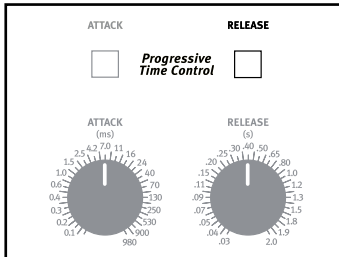

**Progressive Time Control: RELEASE**

The release times can also be switched to automatic based on the Release control: the latter then determines an average value to return the release to.

Use of the Progressive Time Control is especially recommended with complex summed signals.

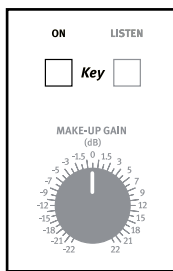

**KEY ON**

KEY ON allows you to use an external signal as the control source for the compressor.

This signal is brought in to the SIDECHAIN INPUT jack on the rear of the unit. Now the control activity of the compressor is determined only by the external signal.

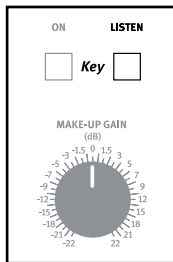

**KEY LISTEN**

Use the KEY LISTEN switch to monitor the external side-chain signal. This makes it easy for example to monitor and adjust a connected equalizer.

Whereas the VU meter normally indicates the in- and output level, enabling KEY LISTEN causes the meter to indicate the side-chain signal. This provides a quick way to check also whether a signal is present.

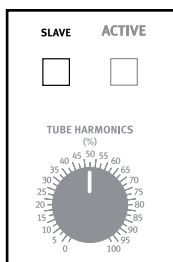

**SLAVE**

This allows you to switch the Kultube to Slave mode so that it can be controlled from the Master device. All the function except for TUBE HARMONICS are now controlled by the Master. Both the Master and all the Slave units now get the same control signal. Also the Slave unit signals are evaluated for analysis.

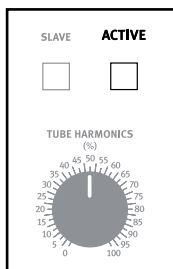

**ACTIVE**

The ACTIVE switch turns on the Kultube. If the device is not turned on, the input signal is fed directly to the output jacks via a relay hard bypass. The ACTIVE switch thus allows for a quick A/B comparison. When the Kultube is turned on the LED on the ACTIVE switch flashes to indicate the warm-up process for the tubes. The unit is ready when the LED no longer flashes.

### THRESHOLD

The THRESHOLD control determines the compressor threshold value. The value scale for the THRESHOLD control indicates the level in dBu. Turning fully left provides no control, and fully right provides compression starting at a level of approximately -40 dBu.

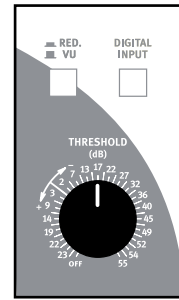

### RATIO

The RATIO control is used to set the ratio between the original signal and the compressed signal. A ratio of 1:4 means that a level increase of 4 dB on the input results in an output change of 1 dB. The more the control is turned right, the more 'dense' the sound becomes. Turned fully right the unit works as a limiter.

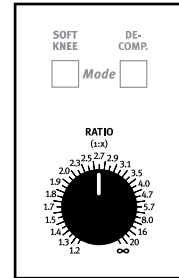

### ATTACK

The ATTACK control determines the time the compressor needs to achieve a reduction of 63% at a level jump of 20 dB. When turned fully left this time is approximately 100 ms, and turned fully right the time is approximately 0.9 s. When Progressive Time Control is enabled the effect is somewhat different: now you are determining the degree to which the fast signal jumps are compressed, whereas the attack time is automatically optimized (adapted). Progressive Time Control mode is often advantageous, since the attack time is only as fast as is necessary for the respective signal. The result is considerably unobtrusive and thus more musical compression behavior without undesired side-effects.

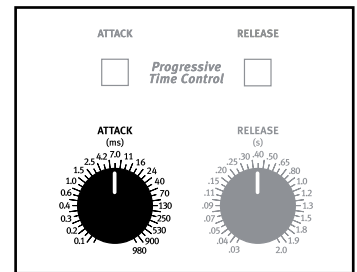

### RELEASE

The RELEASE control is used to set the time the compressor needs to back off by 63% to the original value. Turned fully left this time is approximately 30 ms, or approximately 2 s for fully right. If Progressive Time Control is enabled, the Release control is used to set the average value to which the automatic release time is set back. The more the control is turned right, the slower the averaging. This gives much better results than with the conventional method of rigid release time control especially with complex musical material.

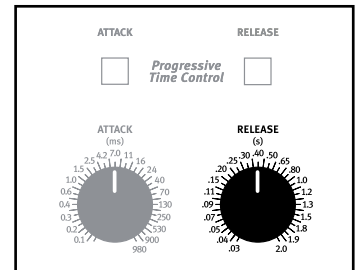

### MAKE UP GAIN

The MAKE UP GAIN controller is used to change the output level within a range of approximately -22 dB to +22 dB. For compression you thus set the value that is indicated on the VU meter in GAIN REDUCT MODE. Actuating the ACTIVE switch makes the volume increase perceptible. With the built-in digital converter option the MAKE UP GAIN control is also used to set the level for the converter. In DE-COMP mode the MAKE UP GAIN control works exactly in reverse: Turning fully CW results in a damping of -22 dB, whereas fully left results in a gain of +22 dB.

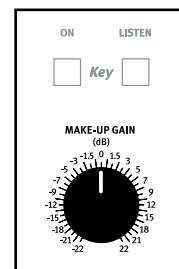

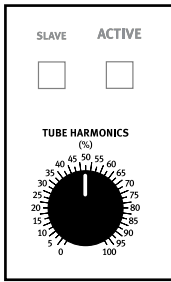

### TUBE HARMONICS

The TUBE HARMONICS control allows you to drive the tube output stage infinitely variable to desperation: the more the control is turned in, the further the tube gets into saturation and the more harmonics are produced.

The output level of this stage is automatically adjusted, i.e. it keeps virtually the same level as the input signal. This allows you to change the entire sonic behavior of the tubes with just one control.

## Operation

### Understanding and enjoying the Kultube

In this section we will describe the individual parameters of the Kultube in greater and use diagrams to enhance your understanding of how and why the Kultube works.

### The Threshold control

This parameter is used to determine at which level (or loudness) the unit even responds by specifying a corresponding threshold value. Sometimes you only need to process individual peaks, and at other times you need to take more drastic action and set the threshold lower.

Fig. 1, „Threshold Input vs. Output“

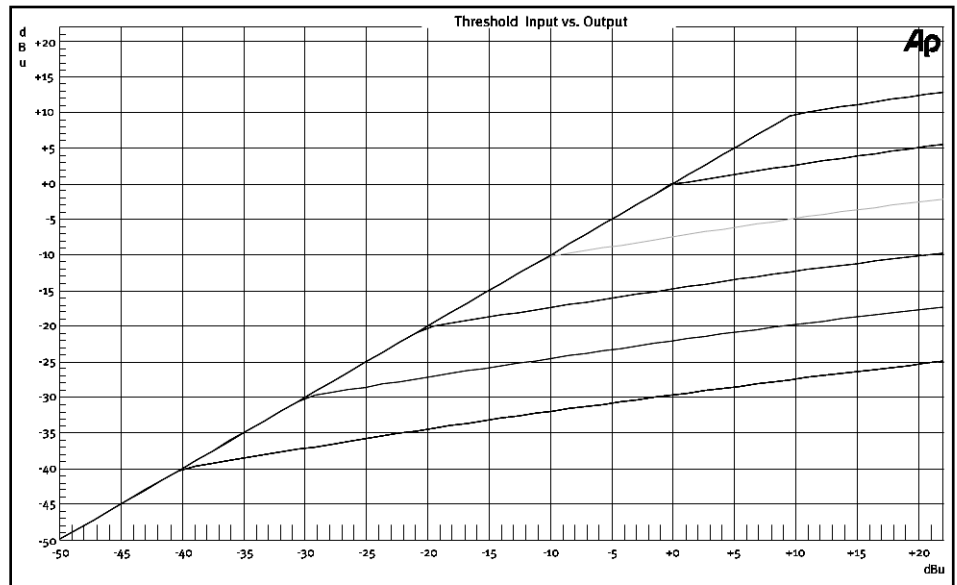

Fig. 1 shows the curves for various threshold settings. The X-axis represents the input level, from -50 dBu to +22 dBu. The Y-axis shows the output level. You can see a definite change where the compressor is starting to work. Before this point the ratio between the in- and output is exactly the same, so that for example an input level of -30 dBu will also be present on the output.

In the area where the curve turns sharply the ratio is approximately 1:4. This means that only a fourth of the dynamic gain is present on the output. A level jump of 8 dB will be reflected by just 2 dB on the output.

### The Ratio control

As indicated above, this determines the ratio between the in- and output level above the threshold setting. The preset value specifies how the input dynamics should behave with respect to the output: a ratio of 1 to 2 means that only half of the dynamic change will be present on the output. At 10 dB of dynamics there will only be 5 dB on the output, whereas using a ratio of 1:8 means 10dB becomes just 1.25 dB, etc.

In short, this determines how much dynamics is allowed to remain. If the compressor is used to process vocals with very large variations in loudness, you would select a high ratio value (1:5 – 1:10) to produce a well-balanced and intelligible signal. When processing summed signals on the other hand, very high settings will be used in part to process only the peaks of the signal. This means careful setting of the threshold control is very important.

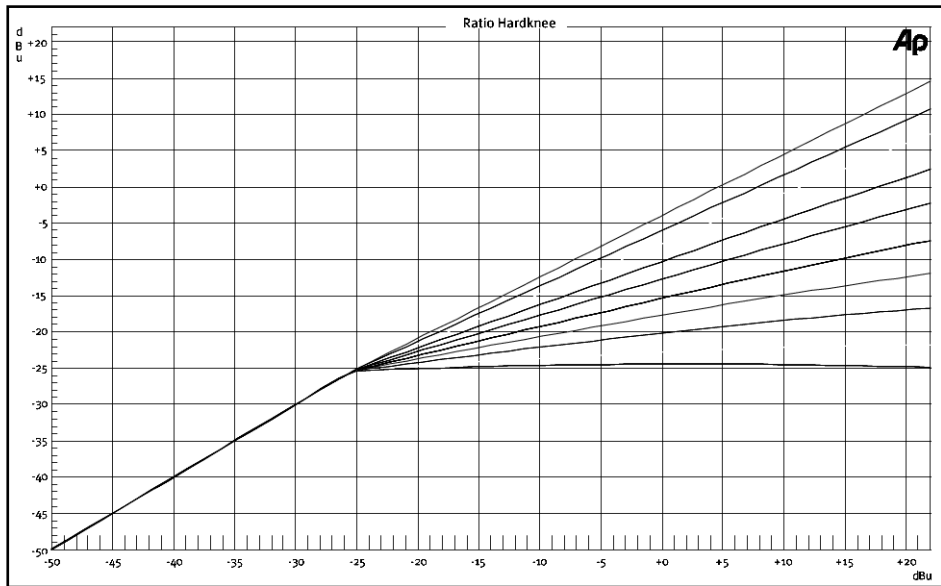

Fig. 2, „Ratio Hardknee“

The slope of the compressor curve may be straight with a sudden rise (hard-knee, Fig. 2), but it may also show a softly curved slope in which compression begins slowly (soft-knee, Fig. 3).

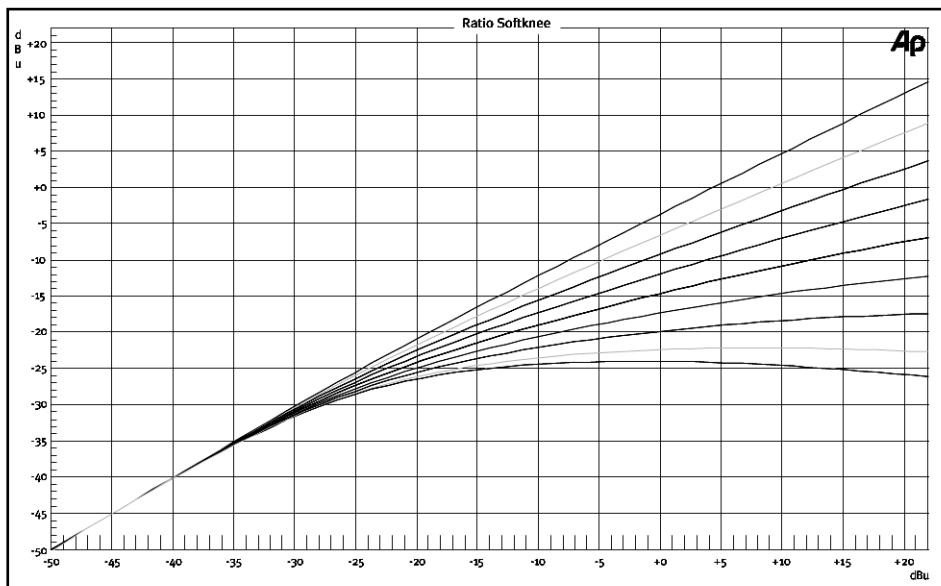

Fig. 3, „Ratio Softknee“

In the latter case the ratio changes depending on the input signal. As the preset threshold value is approached the ratio is comparatively small (1:1.5) and doesn't reach the preset maximum value until high input levels are present. The result is much less conspicuous compression, since the process does not kick in as suddenly as with hard-knee mode. On the other hand, hard-knee results in greater loudness and density of the program material.

When using the de-compressor the ratio is exactly reversed, i.e. an input level change of 2dB for example results in an output of 4dB. The printed ratio values cannot be used here, since they clearly deviate. You should therefore use the de-compressor with care, since it will always make the signals louder. Setting of the threshold control should also be done with caution.

### The Attack control

Among the most important functions of a compressor is controlling the time constants. The attack control determines one of these times, namely the kick-in behavior of the compressor. In general terms this determines the time starting at which the signal should be reduced. This allows you to specify how rapid signal jumps are handled.

How this look with a sinus-burst (test signal) is shown in Fig. 4.

Fig 4  
„Attack Normal“

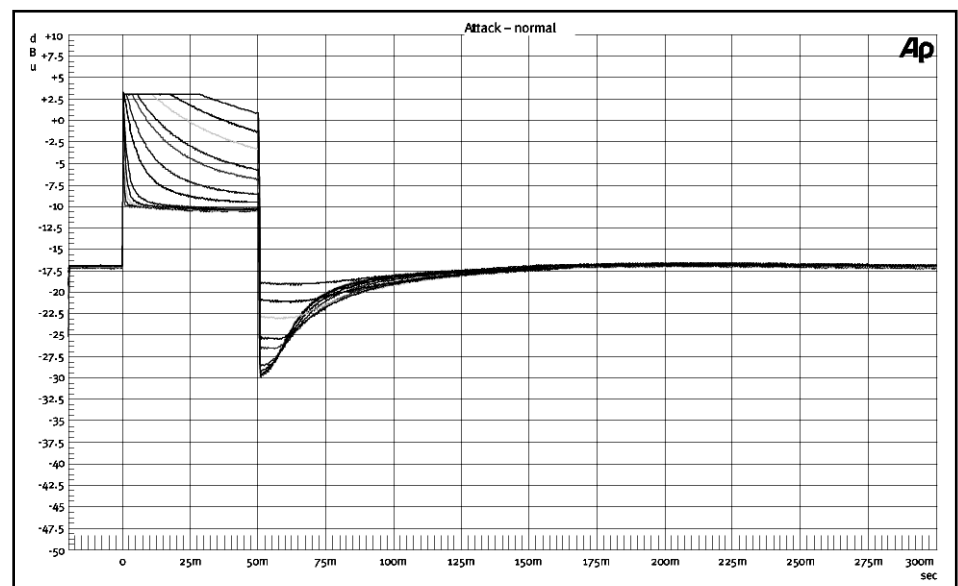

Here you can clearly see that the first part of the burst signal is unprocessed and only responded to when the settings are faster. When attack times are set very short, the compressor responds to even the most rapid transients, so that the peaks are captured. With slower settings transients are allowed to pass untouched – a kind of leveling in which the compressor responds more to the average level. If you are processing a drum loop for example, changing the attack time can cause a few transients to be passed through. Changing the attack control now determines how many transients remain unprocessed.

Using very short values (0.5 ms) allows in part just a half-wave of a signal to remain unprocessed, whereas medium values (10ms) result in a whole series of waveforms to be ignored. This type of response is also frequently used to make transients in a signal more clearly audible.

Processed in this way, drums get more self assertion and sound ,faster'. The best setting is not always easy to find, since you usually need to find a compromise. Very fast settings run the risk of producing audible distortions – especially in the case of low frequencies, since the compressor now tries to control each waveform rise. The corresponding control signal assumes a “saw-tooth” form which distorts the audio signal.

To suppress this effect, you would have to again increase the attack time until the distortions no longer occur. In normal operation the Kultube attack control works exactly as just described. There is a unique feature of the Kultube however that greatly expands the compression possibilities by providing special technologies to achieve optimum results in all situations: the Progressive Time Control (PTC), which is described in the following.

### Progressive Time Control (Attack)

Simply put, the Progressive Time Control (PTC) is an adjustable automatic process that works as follows.

The usual (rigid) attack control of a compressor functions, as described above, such that a resistance value can be varied within the controller circuit to determine the control response time. The main drawback to this, particularly when it comes to complex musical material, is that the setting only applies to a moment, but is not ideal for every moment.

Automatic setting of the attack time (in response to the input signal) has the advantage of making the optimum setting for each moment. For this the changing of the resistance value that determines the attack times needs to be automated. A special circuit determines the momentary ideal attack time and sets the VCF appropriately. These times can vary between 20  $\mu$ s and 980 ms and are set in fractions of a second.

This automatic process is thus a guarantee for perfect compression results, but the PTC in the Kultube goes even a step further: The attack control can be used to determine the intensity with which fast signal jumps are compressed in automatic mode. When you change the attack time using PTC, as for example when processing drum sounds, you can specify the handling of rapid signal jumps while at the same time ensuring that the attack behavior is not affected. A drum loop thus retains its original sonic character while still appearing denser.

Fig. 5 shows the control behavior using a sinus burst as an example. In various

Fig. 5,  
„Attack PTC“

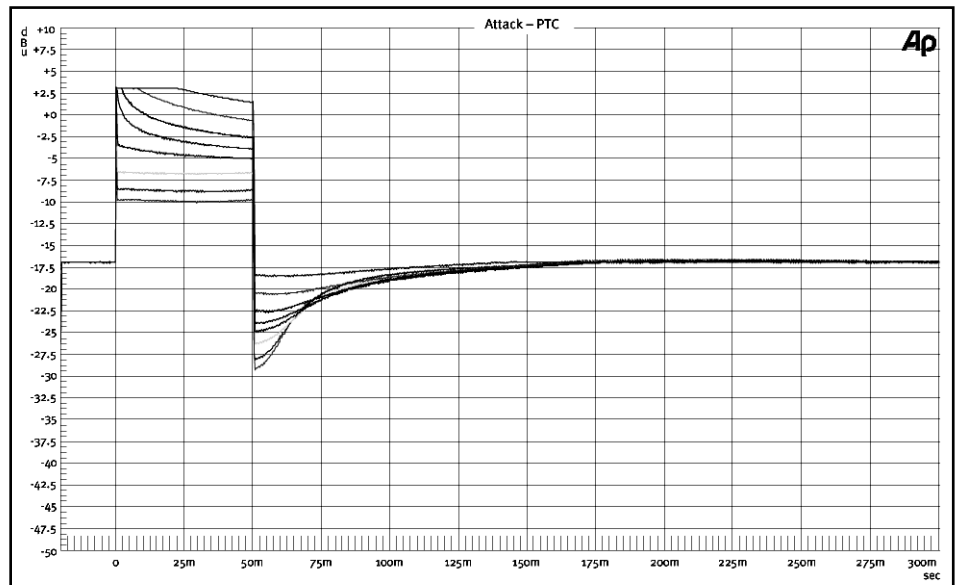

settings it is clearly to see that the burst signal remains almost unchanged in its form; only the intensity changes.

The PTC feature can provide outstanding results not only for percussive signals but also for many other musical signals (vocals, guitar, bass, horns, synthesizers, etc.), since compression is used with the greatest efficiency, is unobtrusive and sounds „natural“. You should feel free to jump right in to experimenting with the PTC and find out what it can do for you.

### The Release control

The Release control is used to determine how long the compressor needs after a reduction to drop back to the original value. How it works is shown in Fig. 6.

Here you see the same sinus burst as for the attack diagrams, but just the last

Fig. 6,  
„Release Normal“

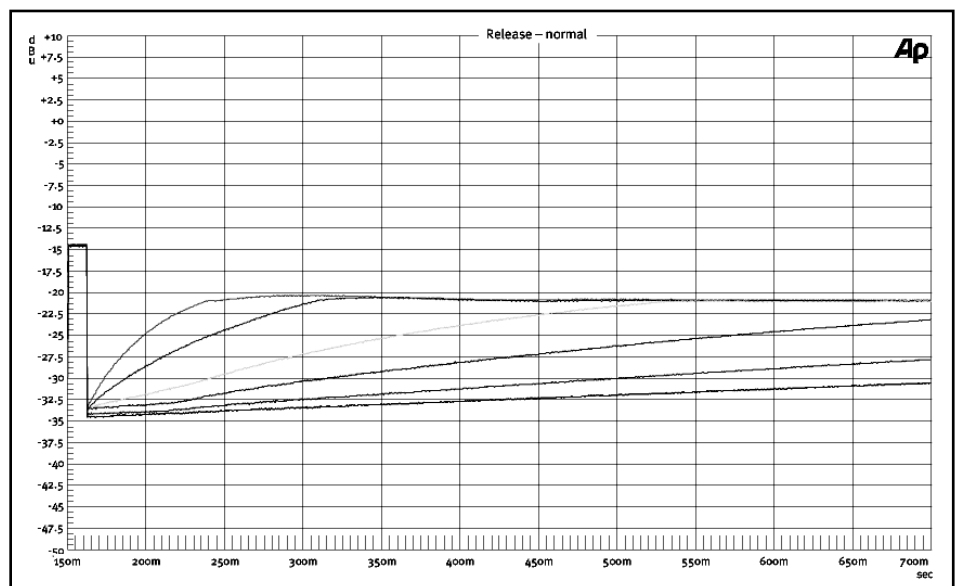

burst-on part is shown. You can clearly see how the times within which the original is reached change with various settings of the release control.

The release parameter is also for the most part responsible for unobtru-

sive compression. This means it is hard to find the perfect setting as with the Attack control – particularly in the case of complex summed signals a fixed release time may hardly be usable. As with the attack times you must always find a compromise: for very fast and short signal peaks (e.g. drums and percussion) you will want to select short release times (100 ms). But this setting is usually unusable in all other parts of the musical piece, since now every single dynamic change will be processed – which will quickly sound very rough and distorted.

By selecting longer release times (1s), the remaining sections will sound quieter, but when short, loud peaks occur your music will start pumping. Here again the PTC will yield better results.

### Progressive Time Control (Release)

Here again we are talking about an automatic release that can be influenced by the release control. When PTC release control is activated, the Kultube calculates an average of the levels that the music signal is providing. Automatic control of the release time now refers to this average value, so that while short, loud peaks are handled correspondingly fast, when it comes to complex material (summed) the system will not respond to each and every little peak near the average.

Furthermore the PTC allows you to affect the averaging: the faster the release time in PTC mode, the more signal components are included in the processing. This means you will want to select rather slower release values for summed signals, whereas drum processing for example will yield the best results using fast settings.

How various settings for a drum loop might look is shown in Figs. 7a-c. Line A represents the control voltage for the discrete gain cell (instead of VCAs), Line B the rectified musical signal, and C the averaging.

For settings with larger averages the change in the release time is easy to recognize. With very small values the control voltage for the Gain Cell “sticks”

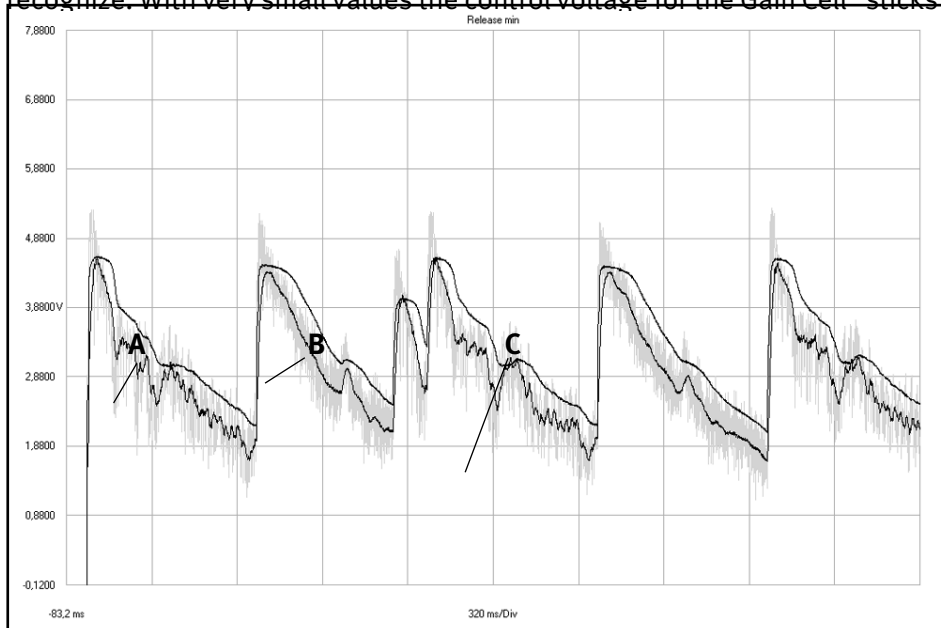

Fig. 7a

Fig. 7b

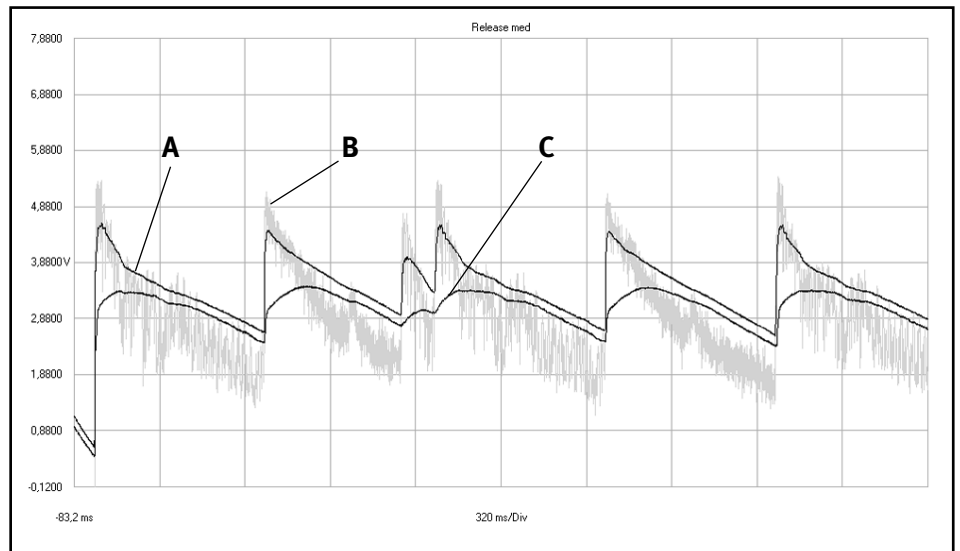
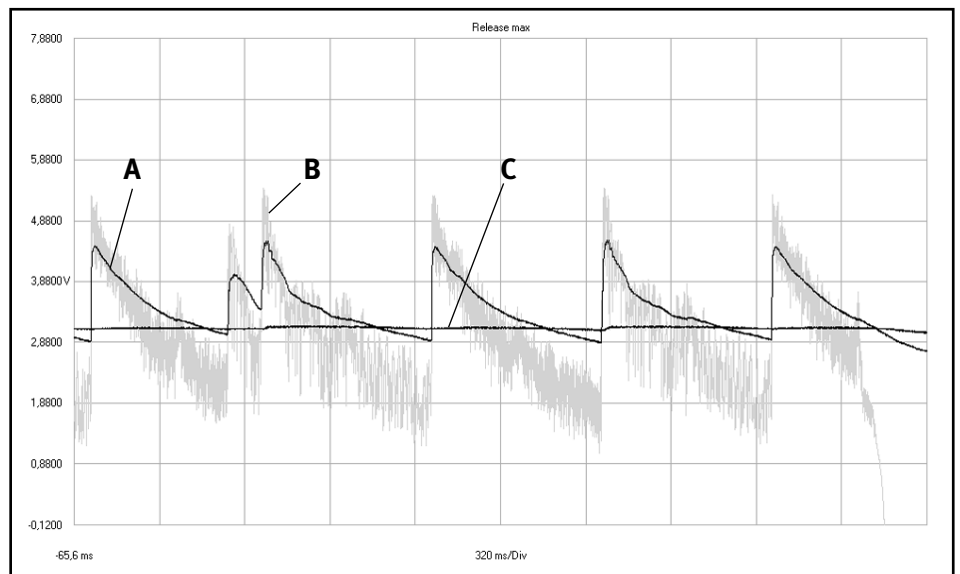

Fig. 7c



to the rectified signal and works almost like an envelope follower.

Fig. 8 on the next page shows the various effects of different release time settings on a sinus burst, although the principle is not as easily seen here.

These changes are most clearly heard in a drum loop with lots of dynamics. Turned fully left (fast averaging) the drums pump and you get lots of volume, whereas turned fully right the control is unobtrusive, but you gain less loudness. For summed signals a mid-range setting (0.8s to 1.5s) is therefore recommended. As in the case of attack control with PTC, release control makes sense not just for sum processing, but can also be used to outstanding advantage with other signal types such as bass, percussion, effects or that at least as problematic as widespread signal type “untrained speaker”, while at the same time greatly simplifying your processing.

Fig 8 „Release – PTC“

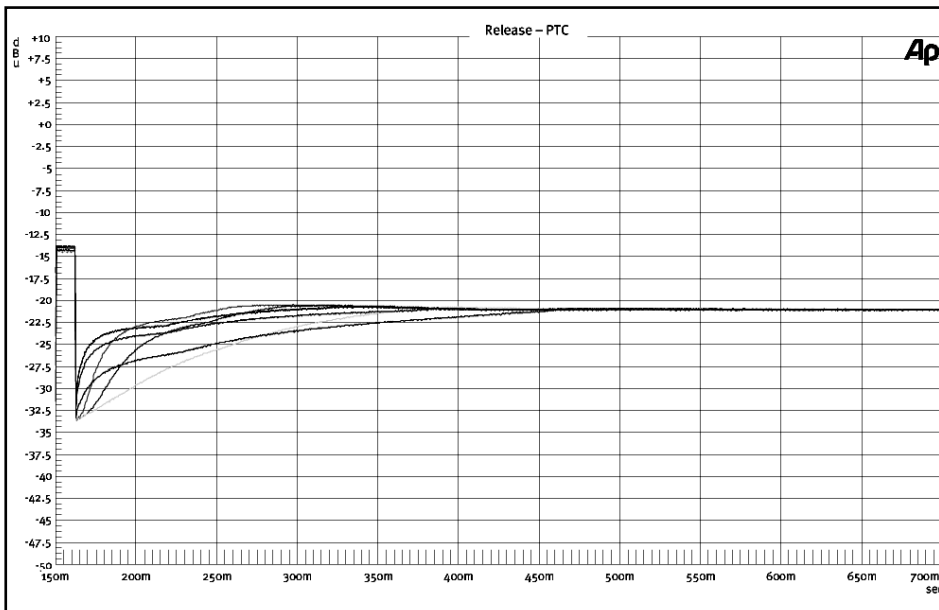

Using and enjoying the Kultube

Applications

Summed signal processing

The main application area for the Kultube is in stereo summed signal compression together with an analog mixing console.

Here the Kultube is looped into the insert paths („Insert Send/Return“). The insert paths are generally in front of the console master fader so that the compressor is driven independent of the master fader settings. If additional effects devices (such as EQ) are located in the same insert loop, the Kultube may be connected either in front or behind – there is no certain order required.

Console:  
Inserts Send/Return

Single track and subgroup processing

Another important application is single track processing (vocals, bass, guitar, strings etc.). The Kultube is looped in the insert paths of the respective channels. Processing is then usually done during mixdown. The same applies of course to subgroup processing for selectively compressing individual instrumental groups (such as drums).

Single tracks and sub-  
groups:  
Channel inserts

## Sidechain

### External compression control

Use of the SIDECHAIN inputs expands the possibilities for controlling compression. A typical application is frequency-selective compression, whereby an external equalizer is used to raise the frequencies at which the compressor should respond or to filter out the frequency band you wish the compressor to ignore.

### Frequency-selective Compression

If a summed signal has a lot of bass for example that you want to preserve, you often run into the problem that the compressor responds strongly to these frequency ranges, making it difficult to process mid- and high frequencies. By using the equalizer to reduce bass frequencies, the Kultube will no longer respond to them as intensely and you can address the other ranges with no difficulty.

### De-Essing

Yet another typical application is de-essing: The corresponding frequency range (around 6-8kHz) is raised so that the compressor engages precisely there to reduce the sibilance. To monitor the filtered signal (i.e. the signal supplied by the EQ), press the KEY LISTEN switch on the front panel. Now you can easily monitor the EQ setting without any additional measures. As soon as you need to use the signal in the side-chain, simply press the KEY ON switch.

### Ducking: Automatically a desired level relation between two signals (e.g. music and microphone)

Another interesting and useful feature is ducking, whereby the side-chain is fed for example with a microphone signal. The music volume is reduced whenever speech is introduced (great for DJs). Other very interesting effects can be obtained by turning on decompression mode with the ducking application. To do this, turn the MAKE UP GAIN controller to full clockwise (means lower in this mode!) and use the Threshold and Ration controllers to determine the desired processing point. Now the loudness of the music signal is controlled by the side-chain, i.e. the louder the side-chain, the louder the music signal becomes. This technique allows you to create totally new sounds! Here is just one example: feed a synthpad to the audio input of the Kultube and a drum loop to the side-chain. The synthpad now gets the same rhythm as the drum loop!

### Ducking & De-Compression: Transferring rhythmic structures to any signal

Note on the VU meter: if the meter indicates output level, pressing the KEY LISTEN switch will show the signal from the side-chain input.

### Multi-channel and 5.1 surround applications

The Kultube lets you use the MULTI CHANNEL LINK function to link any number of devices for multi-channel or surround applications. Simply define a master for controlling all the other units (slaves). Each slave must be defined as a slave using the SLAVE switch on the front panel. All functions except for TUBE HARMONICS output control are not controlled by the master: ACTIVE, THRESHOLD, RATIO, ATTACK, RELEASE, MAKE-UP GAIN, SOFT KNEE, DE-COMP and PTC. Please note that the PTC lights on the slaves will not come on even though the master activates the function. The TUBE HARMONICS control must be set individually on each unit, since this control is not affected by a control voltage – such “remote control” would be extremely complex and would be far out of proportion to the benefit, especially since this setting is generally not changed continuously anyway.

The data from all slave units are also used to create control voltages, so that all units operate with the same control voltage.

We recommend proceeding as follows when working with 5.1 surround: The master unit is responsible for the front left and right channels. A second Kultube processes the rear surround channels (SL & SR) and is operated in slave mode. The third unit (2nd slave) is used to process the center and sub-channel. All the settings are made on the master, with the ACTIVE switch used to conveniently select all the devices. To process certain channels separately you need to deactivate the SLAVE switch only on the corresponding device.

**Multi Channel Link:  
Multi channel or  
surround processing in  
master/slave-mode**

**Recommended configura-  
tion for 5.1 processing**

## Measurements

Frequency range ( <i>100 kHz = -3 dB</i> ) .....	10 Hz-150 kHz
Common mode rejection ( <i>@ 0 dBu</i> ) .....	1 kHz: > 80 dB / 10 kHz: > 65 dB
THD & N ( <i>@ 0 dBu</i> ) .....	> 82 dB
S/N ( <i>A-weighted</i> ) .....	90 dBu

## Inputs

Input impedance .....	Line: 20 kOhm
Max. input level .....	Line: +22 dBu

## Outputs

Max. output level ( <i>XLR &amp; Jack</i> ) .....	+22 dBu
Output impedance .....	< 50 Ohm

## Power Supply

Toroidal transformer .....	30 VA
Fuses .....	230 V/50 Hz: 500 mA
...	115 V/60 Hz: 800 mA

## Dimensions

Standard-EIA-Housing ( <i>19 inch/2U</i> ) .....	482 x 88 x 210 mm
Weight .....	4,3 kg